

S. GULLICKSEN.
Bolt and Rod Griper.

No. 218,018.

Patented July 29, 1879.

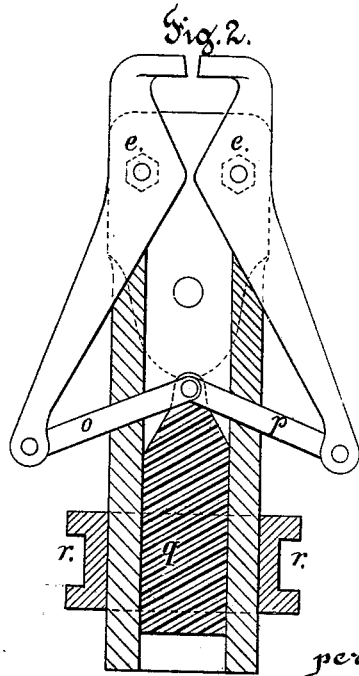
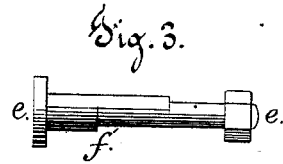
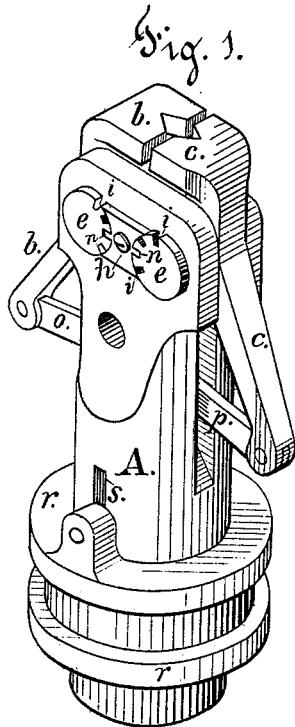

Witnesses:
W. Lloyd Duckett
W. F. Clark

Inventor
Sverin Gullicksen
per J. L. Boone
Attorneys

UNITED STATES PATENT OFFICE.

SEVERIN GULLICKSEN, OF SAN FRANCISCO, CALIFORNIA.

IMPROVEMENT IN BOLT AND ROD GRIPERS.

Specification forming part of Letters Patent No. **218,018**, dated July 29, 1879; application filed April 16, 1879.

To all whom it may concern:

Be it known that I, SEVERIN GULLICKSEN, of the city and county of San Francisco, State of California, have invented an Improved Bolt and Rod Griper; and I do hereby declare that the following is a full, clear, and exact description thereof, reference being had to the accompanying drawings.

My invention has reference to certain improvements in the gripers which are secured to lathe-spindles for the purpose of holding bolts and rods so that they can be turned.

Referring to the accompanying drawings, Figure 1 is a perspective of the griper. Fig. 2 is a section of the griper, and Fig. 3 is a detached view of bolt with eccentric.

Let A represent the tubular head of the griper, one end of which is arranged to be secured upon the end of the lathe-spindle, while the gripping-jaws *b c* are attached by bolts to its opposite end. The outer end of the head A is slotted lengthwise, and the gripers *b c* are placed in the slot opposite each other and secured by bolts *e*, so that their gripping ends extend beyond the end of the head, while their opposite ends extend back so as to form levers, by means of which the jaws are operated.

In the middle of each bolt *e*, where it passes through the jaw, I make an eccentric, *f*, thus forming each bolt into a slight crank, so that by rotating the bolts the jaws can be moved toward or from each other to accommodate bolts or rods of different diameters.

In the rim of the head of each bolt I make a number of notches, *i i*, at intervals apart, and when the bolts have been turned so as to set the jaws at the desired distance apart, and so as to bring two of these notches in line opposite each other, I introduce a plate, *h*, between them, which has a projection or tooth, *n*, at each end, so that the projections or teeth will enter the two opposite notches. I then

secure the plate to the head by means of a screw, as shown, thus preventing the bolts from rotating, and locking the two eccentrics firmly in position.

The rear or lever ends of the gripers *b c* are connected through the slot in the griper-head by the two toggle-levers *o p*, the meeting ends of which are attached to one end of a sliding rod, *q*. This rod moves in the tubular head and is connected with a sliding ring, *r*, which moves on the outside of the head by means of pins passing through slots *s* in the head. Now, by moving this outside ring *r* backward the toggles are straightened, so as to force the lever-arms outward and close the gripping-jaws upon the rod or bolt; but when the ring *r* is moved forward the toggles are broken, so as to draw the lever-arms together and open the jaws. The ring *r* can be moved by means of a lever.

By this arrangement I can adjust the griper-jaws so that bolts of different diameters can be held between them, and yet permit the toggles to straighten and become set, no difference what size of bolt the jaws are holding.

Having thus described my invention, what I claim, and desire to secure by Letters Patent, is—

The gripping-jaws *b c*, mounted in the head A upon the eccentric or crank bolts *e*, and having their lever ends connected by toggles *o p*, in combination with the notches *i i* in the bolt-heads and the locking-plate *h*, all combined and arranged to operate substantially as and for the purpose described.

In witness whereof I have hereunto set my hand and seal.

SEVERIN GULLICKSEN. [L. S.]

Witnesses:

W. FLOYD DUCKETT,
W. F. CLARK.